

MICRON**ValueTRUE™**

True Planetary Gearheads

Ready for Immediate Delivery	
Precision	4 arc-minutes
Frame Sizes	60 mm, 75 mm, 90 mm, 100 mm, 115 mm, 140 mm, 180 mm and 220 mm
Torque Capacity	up to 2970 Nm
Ratio Availability	4:1 thru 100:1
Mounting System	RediMount™
Both in-line and right angles available	

- ValueTRUE is a new high-performance, price-competitive line of Micron True Planetary Gearheads
- Low cost– 30% less than typical market pricing
- Helical Crowned True Planetary gearing improved load capacity, lower backlash and smoother and quieter operation compared to non-helical gearheads
- Ultra Precision – 4 arc-mins of backlash
- Drop-in, low-cost replacement for most common helical gearheads
- Stainless steel output housing provides rock-solid durability, suitable for environmentally sensitive applications



TRUE™ Planetary Gearheads

ValueTRUE

Helical True Planetary Gearheads

Part Number	Stages	Backlash (arc-min)	Efficiency	Weight kg [lbs.]	Ratio Availability
VT006	1	4	95%	2 [4.4]	4:1, 5:1, 7:1, 10:1
	2	5	90%	2.5 [5.5]	16:1, 20:1, 25:1, 28:1, 35:1, 40:1, 50:1, 70:1, 100:1
VT075	1	4	95%	2.5 [5.5]	4:1, 5:1, 7:1, 10:1
	2	5	90%	3.0 [6.6]	16:1, 20:1, 25:1, 28:1, 35:1, 40:1, 50:1, 70:1, 100:1
VT090	1	4	95%	2.5 [5.5]	4:1, 5:1, 7:1, 10:1
	2	5	90%	3.0 [6.6]	16:1, 20:1, 25:1, 28:1, 35:1, 40:1, 50:1, 70:1, 100:1
VT010	1	4	95%	6 [13]	4:1, 5:1, 7:1, 10:1
	2	5	90%	8 [18]	16:1, 20:1, 25:1, 28:1, 35:1, 40:1, 50:1, 70:1, 100:1
VT115	1	4	95%	6 [13]	4:1, 5:1, 7:1, 10:1
	2	5	90%	8 [18]	16:1, 20:1, 25:1, 28:1, 35:1, 40:1, 50:1, 70:1, 100:1
VT014	1	4	95%	14 [31]	4:1, 5:1, 7:1, 10:1
	2	5	90%	18 [40]	16:1, 20:1, 25:1, 28:1, 35:1, 40:1, 50:1, 70:1, 100:1
VT018	1	4	95%	40 [88]	4:1, 5:1, 7:1, 10:1
	2	5	90%	45 [99]	16:1, 20:1, 25:1, 28:1, 35:1, 40:1, 50:1, 70:1, 100:1
VT022	1	4	95%	74 [162]	4:1, 5:1, 7:1, 10:1
	2	5	90%	95 [209]	16:1, 20:1, 25:1, 28:1, 35:1, 40:1, 50:1, 70:1, 100:1
VTR006	1	5	93%	3 [6.6]	8:1, 10:1, 12:1, 14:1, 15:1, 16:1, 20:1, 25:1, 28:1, 30:1, 35:1, 40:1, 50:1
VTR075	1	5	93%	5.3 [11.1]	8:1, 10:1, 12:1, 14:1, 15:1, 16:1, 20:1, 25:1, 28:1, 30:1, 35:1, 40:1, 50:1
VTR090	1	5	93%	5.3 [11.1]	8:1, 10:1, 12:1, 14:1, 15:1, 16:1, 20:1, 25:1, 28:1, 30:1, 35:1, 40:1, 50:1
VTR010	1	5	93%	12 [26.2]	4:1, 5:1, 8:1, 10:1, 12:1, 14:1, 15:1, 16:1, 20:1, 25:1, 28:1, 30:1, 35:1, 40:1, 50:1
VTR115	1	5	93%	12 [26.2]	4:1, 5:1, 8:1, 10:1, 12:1, 14:1, 15:1, 16:1, 20:1, 25:1, 28:1, 30:1, 35:1, 40:1, 50:1
VTR014	1	5	93%	29 [64]	4:1, 5:1, 8:1, 10:1, 12:1, 14:1, 15:1, 16:1, 20:1, 25:1, 28:1, 30:1, 35:1, 40:1, 50:1
VTR018	1	5	93%	48 [106]	4:1, 5:1, 8:1, 10:1, 12:1, 14:1, 15:1, 16:1, 20:1, 25:1, 28:1, 30:1, 35:1, 40:1, 50:1

All ratios in frame size 60, 75, 100 and 140 are available to ship in 24 hours through the Gearhead Express Program.

- * Efficiency measured at 100% rated torque
- * Backlash is maximum for the life of the gearhead
- * For other ratios, please contact factory

MICRON

ValueTRUE™

Helical True Planetary Gearheads

VT006
VT075
VT010
VT014
VT018
VT022

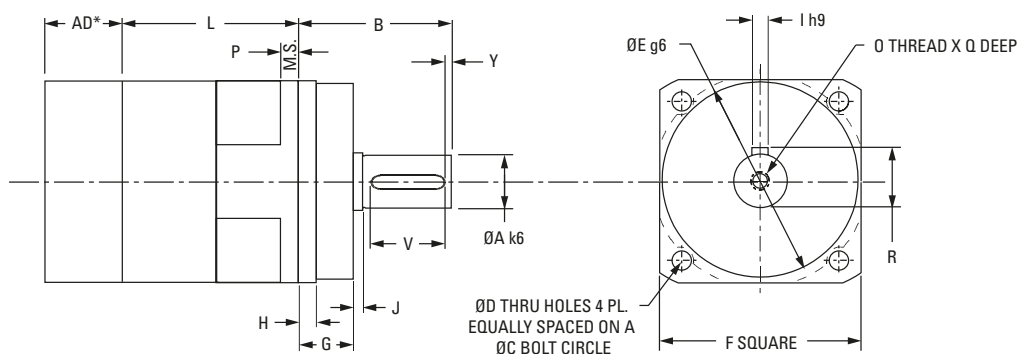

VT090
VT115

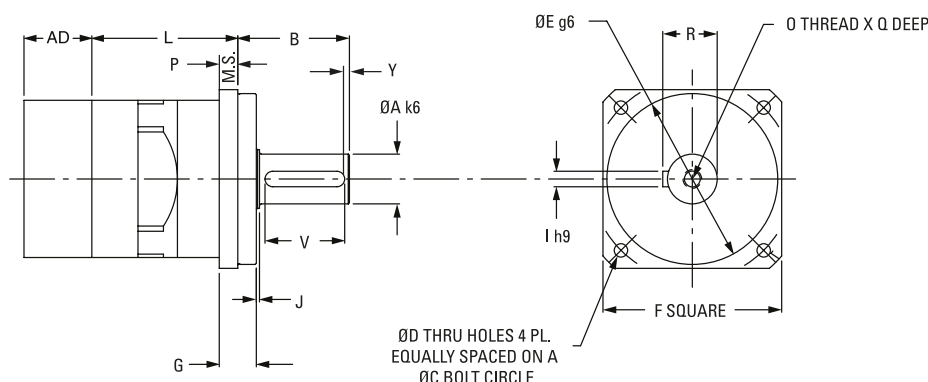

Inline Dimensions

Part Number	F	A	B	Y	V	R	I	J	E
	Flange Square mm [in.]	Output Shaft Diameter mm [in.]	Output Shaft Length mm [in.]	Shaft End Distance mm [in.]	Keyway Length mm [in.]	Keyway Height mm [in.]	Key Square mm [in.]	Shoulder Length mm [in.]	Pilot Diameter mm [in.]
VT006	61 [2.40]	16 [0.63]	48 [1.89]	1 [0.04]	25 [0.98]	18 [0.71]	5 [0.20]	1 [0.04]	60 [2.36]
VT075	75 [2.95]	22 [0.86]	56 [2.20]	1,5 [0.06]	32 [1.26]	24,5 [0.97]	6 [0.24]	1 [0.04]	70 [2.75]
VT090	90 [3.54]	22 [0.86]	48 [1.89]	1,5 [0.06]	32 [1.26]	24,5 [0.97]	6 [0.24]	1 [0.04]	80 [1.48]
VT010	101 [3.98]	32 [1.26]	88 [3.46]	3 [0.12]	50 [1.97]	35 [1.38]	10 [0.39]	2 [0.08]	90 [3.54]
VT115	115 [4.53]	32 [1.26]	72 [2.83]	3 [0.12]	50 [1.97]	35 [1.38]	10 [0.39]	2 [0.08]	110 [4.33]
VT014	141 [5.55]	40 [1.57]	112 [4.41]	5 [0.20]	70 [2.76]	43 [1.69]	12 [0.47]	3 [0.12]	130 [5.11]
VT018	182 [7.17]	55 [2.17]	112 [4.41]	6 [0.24]	70 [2.76]	59 [2.32]	16 [0.63]	3 [0.12]	160 [6.30]
VT022	220 [8.66]	75 [2.95]	143 [5.63]	7 [0.28]	90 [3.54]	79.5 [3.13]	20 [0.78]	3 [0.12]	180 [7.08]

Part Number	G Pilot Length mm [in.]	P Flange Thickness mm [in.]	H Effective Pilot Length mm [in.]	L Length mm [in.]		C Bolt Circle mm [in.]	D Bolt Hole mm [in.]	O Output Shaft Thread mm [in.]	Q Thread Depth mm [in.]
				Length mm [in.]					
				4:1 - 10:1	16:1 - 100:1				
VT006	18 [0.71]	7 [0.28]	7 [0.28]	57 [2.24]	105,4 [4.15]	68 [2.68]	5,6 [0.22]	M5	19 [0.75]
VT075	20 [0.79]	8 [0.31]	7 [0.28]	60 [2.36]	117 [4.60]	85 [3.35]	7 [0.28]	M8	19 [0.75]
VT090	12 [0.47]	10 [0.39]	-	68 [2.67]	125 [4.92]	100 [3.94]	6,6 [0.26]	M8	19 [0.75]
VT010	28 [1.10]	10 [0.39]	12 [0.47]	78 [3.09]	146 [5.75]	120 [4.72]	9 [0.34]	M12	20 [0.80]
VT115	12 [0.47]	12 [0.47]	-	94 [3.72]	162 [6.38]	130 [5.118]	9 [0.34]	M12	20 [0.80]
VT014	27 [1.06]	13 [0.51]	14 [0.55]	110,5 [4.35]	195 [7.67]	165 [6.50]	11 [0.43]	M12	20 [0.80]
VT018	27 [1.06]	15 [0.59]	13 [0.51]	136 [5.35]	242,3 [9.54]	215 [8.46]	13,5 [0.53]	M20	42 [1.65]
VT022	35 [1.38]	17 [0.67]	18 [0.71]	142,7 [5.62]	243,6 [9.60]	250 [9.84]	17 [0.67]	M20	42 [1.65]

All ratios in frame size 60, 75, 100 and 140 are available to ship in 24 hours through the Gearhead Express Program.

¹ Ratios are exact, higher ratios are also available, consult factory.
T_r = Rated output torque at rated speed for specific hours of life.

T_{peak} = Allowable momentary peak torque for emergency stop or heavy shock loading.
J = Mass moment of inertia reflected to the input shaft (including pinion assembly).

TRUE™ Planetary Gearheads

ValueTRUE 90

Helical Right Angle Gearheads

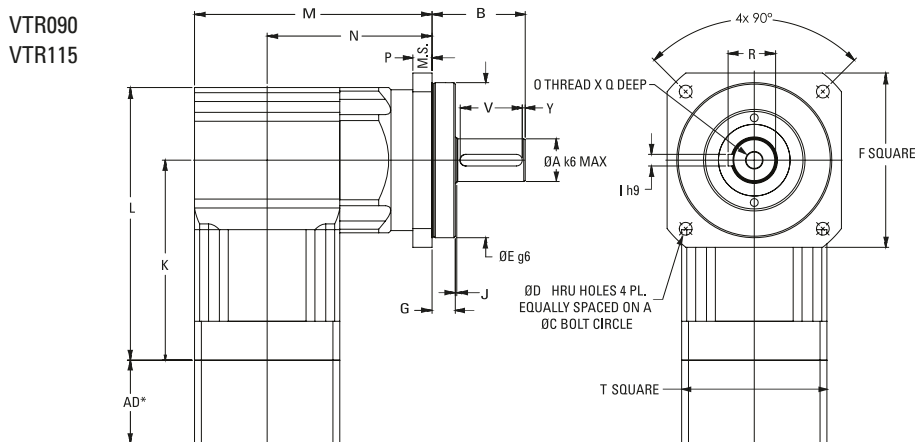
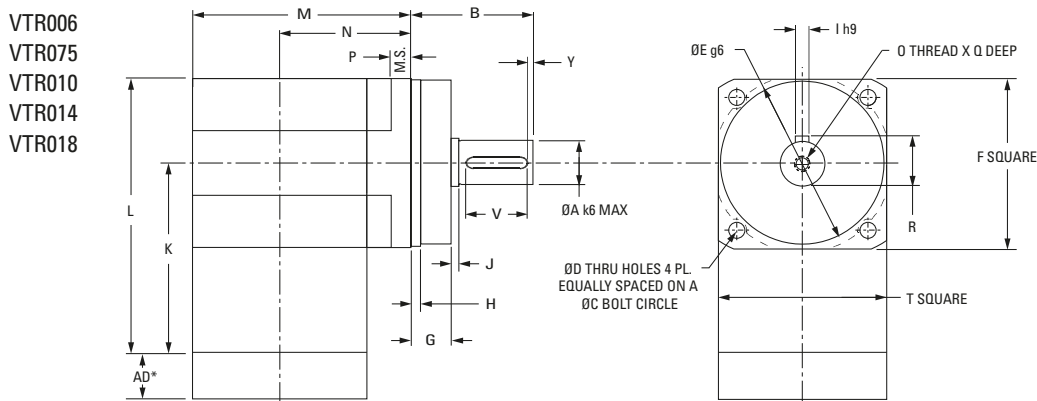

Right Angle Dimensions

Part Number	F	A	B	Y	V	R	I	J	O	Q	E	G
	Output Flange Square mm [in.]	Output Shaft Diameter mm [in.]	Output Shaft Length mm [in.]	Shaft End Distance mm [in.]	Keyway Length mm [in.]	Keyway Height mm [in.]	Key Square mm [in.]	Shoulder Length mm [in.]	Output Shaft Thread mm [in.]	Thread Depth mm [in.]	Pilot Diameter mm [in.]	Pilot Length mm [in.]
VTR006	61 [2.40]	16 [0.63]	48 [1.89]	1 [0.04]	25 [0.98]	18 [0.71]	5 [0.20]	1 [0.04]	M5	19 [0.75]	60 [2.36]	18 [0.71]
VTR075	75 [2.95]	22 [0.86]	56 [2.20]	1,5 [0.06]	32 [1.26]	24,5 [0.97]	6 [0.24]	1 [0.04]	M8	19 [0.75]	70 [2.75]	20 [0.79]
VTR090	90 [3.54]	22 [0.86]	48 [1.89]	1,5 [0.06]	32 [1.26]	24,5 [0.97]	6 [0.24]	1 [0.04]	M8	19 [0.75]	80 [1.48]	12 [0.47]
VTR010	101 [3.98]	32 [1.26]	88 [3.46]	3 [0.12]	50 [1.97]	35 [1.38]	10 [0.39]	2 [0.08]	M12	20 [0.80]	90 [3.54]	28 [1.10]
VTR115	115 [4.53]	32 [1.26]	72 [2.83]	3 [0.12]	50 [1.97]	35 [1.38]	10 [0.39]	2 [0.08]	M12	20 [0.80]	110 [4.33]	24 [0.94]
VTR014	141 [5.55]	40 [1.57]	112 [4.41]	5 [0.20]	70 [2.76]	43 [1.69]	12 [0.47]	3 [0.12]	M12	20 [0.80]	130 [5.11]	27 [1.06]
VTR018	182 [7.17]	55 [2.17]	112 [4.41]	6 [0.24]	70 [2.76]	59 [2.32]	16 [0.63]	3 [0.12]	M20	42 [1.65]	160 [6.29]	27 [1.06]

Part Number	P	H	L	K	C	D	M		N		T
	Flange Thickness mm [in.]	Effective Pilot Length mm [in.]	Length mm [in.]	Distance to Output CL mm [in.]	Bolt Circle mm [in.]	Bolt Hole mm [in.]	Housing Width mm [in.]		Distance to Input CL mm [in.]		Input Flange Square mm [in.]
							All other ratios	4:1 & 5:1 only	All other ratios	4:1 & 5:1 only	
VTR006	7 [0.28]	7 [0.28]	109,5 [4.31]	79 [3.11]	68 [2.68]	5,6 [0.22]	95 [3.75]	95 [3.75]	65 [2.55]	65 [2.55]	61 [2.40]
VTR075	8 [0.31]	7 [0.28]	141 [5.55]	103 [4.05]	85 [3.35]	7 [0.28]	114,5 [4.51]	114,5 [4.51]	77 [3.04]	77 [3.04]	75 [2.95]
VTR090	10 [0.39]	-	141 [5.55]	103 [4.05]	100 [3.94]	6,6 [0.26]	122,5 [4.82]	122,5 [4.82]	85 [3.35]	85 [3.35]	75 [2.95]
VTR010	10 [0.39]	12 [0.47]	193 [7.60]	142,5 [5.61]	120 [4.72]	9 [0.34]	149 [5.88]	157 [6.19]	99 [3.89]	107 [4.20]	101 [3.98]
VTR115	12 [0.47]	-	193 [7.60]	142,5 [5.61]	130 [5.118]	9 [0.34]	165 [6.51]	173 [6.82]	114,8 [4.52]	123 [4.83]	101 [3.98]
VTR014	13 [0.51]	14 [0.55]	231 [9.09]	160 [6.23]	165 [6.50]	11 [0.43]	222 [8.74]	222 [8.74]	151 [5.95]	151 [5.95]	142 [5.59]
VTR018	15 [0.59]	13 [0.51]	319 [12.60]	228 [8.97]	215 [8.46]	13,5 [0.53]	273 [10.76]	301 [11.83]	182 [7.18]	210 [8.25]	182 [7.17]

MICRON**ValueTRUE™ Helical True Planetary Gearheads**

Inline Torque: VT006 - VT010

Performance Specifications

Part Number	Ratio	20000 Hour Life			T _{peak} Nm [in.-lb.]	J kg-cm ² [in.-lb.-sec ² x10 ⁻⁴]	Torsional Stiffness Nm/arc-min [in.-lb./arc-min]	
		T _r (1000 rpm) Nm [in.-lb.]	T _r (3000 rpm) Nm [in.-lb.]	T _r (5000 rpm) Nm [in.-lb.]				
VT006	VT006-004	4:1	42 [375]	32 [290]	28 [248]	91 [802]	0.20 [1.80]	2.36 [20.9]
	VT006-005	5:1	41 [364]	34 [302]	30 [259]	88 [779]	0.13 [1.16]	2.30 [20.4]
	VT006-007	7:1	40 [347]	36 [319]	32 [276]	84 [743]	0.11 [0.96]	2.18 [19.4]
	VT006-010	10:1	22 [194]	19 [167]	17 [156]	79 [703]	0.10 [0.85]	1.74 [15.4]
	VT006-016	16:1	47 [410]	43 [383]	41 [369]	99 [878]	0.16 [1.44]	2.40 [21.3]
	VT006-020	20:1	47 [416]	44 [42]	42 [375]	100 [887]	0.16 [1.44]	2.36 [20.9]
	VT006-025	25:1	45 [401]	42 [376]	41 [364]	96 [853]	0.16 [1.44]	2.32 [20.5]
	VT006-028	28:1	48 [423]	45 [398]	43 [384]	102 [899]	0.16 [1.44]	2.21 [19.6]
	VT006-035	35:1	46 [408]	43 [384]	42 [127]	97 [864]	0.10 [0.85]	2.29 [20.3]
	VT006-040	40:1	49 [430]	46 [406]	44 [394]	103 [910]	0.10 [0.85]	2.40 [21.3]
	VT006-050	50:1	47 [415]	44 [392]	43 [381]	99 [874]	0.10 [0.85]	2.36 [20.9]
VT006-070	70:1	44 [662]	42 [373]	41 [362]	93 [822]	0.10 [0.85]	2.21 [19.6]	
VT006-100	100:1	29 [256]	25 [224]	23 [211]	86 [766]	0.10 [0.85]	1.83 [16.1]	
VT075	VT075-004	4:1	76 [671]	67 [587]	57 [503]	161 [1423]	0.46 [4.10]	6.30 [55.7]
	VT075-005	5:1	74 [651]	67 [591]	59 [525]	157 [1383]	0.38 [3.40]	6.17 [54.6]
	VT075-007	7:1	70 [621]	64 [569]	61 [541]	149 [1322]	0.31 [2.80]	5.46 [48.3]
	VT075-010	10:1	40 [348]	34 [300]	32 [279]	141 [1254]	0.27 [2.40]	4.01 [35.6]
	VT075-016	16:1	84 [738]	77 [686]	75 [659]	177 [1569]	0.31 [2.80]	6.62 [58.6]
	VT075-020	20:1	85 [747]	79 [698]	76 [671]	179 [1586]	0.31 [2.80]	6.48 [57.3]
	VT075-025	25:1	82 [721]	77 [675]	74 [651]	173 [1528]	0.31 [2.80]	6.36 [56.3]
	VT075-028	28:1	86 [761]	81 [714]	77 [689]	182 [1610]	0.28 [2.50]	5.81 [51.4]
	VT075-035	35:1	83 [734]	78 [690]	76 [667]	175 [1549]	0.16 [1.40]	6.01 [53.2]
	VT075-040	40:1	87 [775]	83 [730]	80 [707]	185 [1632]	0.16 [1.40]	6.63 [58.7]
	VT075-050	50:1	85 [747]	80 [706]	77 [683]	177 [1569]	0.16 [1.40]	6.50 [57.5]
VT075-070	70:1	80 [706]	76 [669]	74 [650]	167 [1475]	0.16 [1.40]	5.83 [51.6]	
VT075-100	100:1	52 [462]	46 [405]	43 [380]	156 [1376]	0.15 [1.30]	4.05 [35.8]	
VT090	VT090-004	4:1	76 [671]	67 [587]	57 [503]	161 [1423]	0.46 [4.10]	6.30 [55.7]
	VT090-005	5:1	74 [651]	67 [591]	59 [525]	157 [1383]	0.38 [3.40]	6.17 [54.6]
	VT090-007	7:1	70 [621]	64 [569]	61 [541]	149 [1322]	0.31 [2.80]	5.46 [48.3]
	VT090-010	10:1	40 [348]	34 [300]	32 [279]	141 [1254]	0.27 [2.40]	4.01 [35.6]
	VT090-016	16:1	84 [738]	77 [686]	75 [659]	177 [1569]	0.31 [2.80]	6.62 [58.6]
	VT090-020	20:1	85 [747]	79 [698]	76 [671]	179 [1586]	0.31 [2.80]	6.48 [57.3]
	VT090-025	25:1	82 [721]	77 [675]	74 [651]	173 [1528]	0.31 [2.80]	6.36 [56.3]
	VT090-028	28:1	86 [761]	81 [714]	77 [689]	182 [1610]	0.28 [2.50]	5.81 [51.4]
	VT090-035	35:1	83 [734]	78 [690]	76 [667]	175 [1549]	0.16 [1.40]	6.01 [53.2]
	VT090-040	40:1	87 [775]	83 [730]	80 [707]	185 [1632]	0.16 [1.40]	6.63 [58.7]
	VT090-050	50:1	85 [747]	80 [706]	77 [683]	177 [1569]	0.16 [1.40]	6.50 [57.5]
VT090-070	70:1	80 [706]	76 [669]	74 [650]	167 [1475]	0.16 [1.40]	5.83 [51.6]	
VT090-100	100:1	52 [462]	46 [405]	43 [380]	156 [1376]	0.15 [1.30]	4.05 [35.8]	
VT010	VT010-004	4:1	221 [1954]	158 [1405]	136 [1206]	463 [4093]	1.58 [14.00]	23.1 [204]
	VT010-005	5:1	216 [1908]	166 [1465]	142 [1257]	451 [3991]	1.36 [12.00]	20.5 [182]
	VT010-007	7:1	206 [1825]	176 [1562]	151 [1340]	433 [3830]	0.97 [8.60]	19.0 [168]
	VT010-010	10:1	115 [1016]	99 [872]	92 [808]	411 [3640]	0.90 [8.00]	13.0 [115]
	VT010-016	16:1	246 [2174]	227 [2010]	206 [1827]	518 [4577]	1.10 [9.70]	24.6 [218]
	VT010-020	20:1	249 [2205]	231 [2046]	221 [1954]	524 [4637]	1.10 [9.70]	21.9 [194]
	VT010-025	25:1	241 [2131]	224 [1985]	216 [1908]	506 [4477]	1.10 [9.70]	21.9 [194]
	VT010-028	28:1	254 [2248]	237 [2098]	228 [2018]	533 [4718]	0.94 [8.30]	19.0 [168]
	VT010-035	35:1	246 [2172]	230 [2033]	221 [1959]	514 [4549]	0.79 [7.00]	18.8 [167]
	VT010-040	40:1	259 [2291]	243 [2149]	234 [2075]	542 [4794]	0.79 [7.00]	24.7 [219]
	VT010-050	50:1	250 [2212]	235 [2081]	228 [2012]	521 [4615]	0.78 [6.90]	21.7 [192]
VT010-070	70:1	237 [2094]	223 [1977]	217 [1916]	491 [4349]	0.78 [6.90]	19.0 [168]	
VT010-100	100:1	153 [1354]	134 [1185]	126 [1112]	459 [4059]	0.78 [6.90]	15.5 [137]	

All ratios in frame size 60, 75, 100 and 140 are available to ship in 24 hours through the Gearhead Express Program.

TRUE™ Planetary Gearheads

ValueTRUE Helical True Planetary Gearheads

Inline Torque: VT115 - VT022

Performance Specifications

Part Number	Ratio	20000 Hour Life			T _{peak} Nm [in.-lb.]	J kg-cm ² [in.-lb.-sec ² x10 ⁻⁴]	Torsional Stiffness Nm/arc-min [in.-lb./arc-min]	
		T _r (1000 rpm) Nm [in.-lb.]	T _r (3000 rpm) Nm [in.-lb.]	T _r (5000 rpm) Nm [in.-lb.]				
VT115	VT115-004	4:1	221 [1954]	158 [1405]	136 [1206]	463 [4093]	1.58 [14.00]	23.1 [204]
	VT115-005	5:1	216 [1908]	166 [1465]	142 [1257]	451 [3991]	1.36 [12.00]	20.5 [182]
	VT115-007	7:1	206 [1825]	176 [1562]	151 [1340]	433 [3830]	0.97 [8.60]	19.0 [168]
	VT115-010	10:1	115 [1016]	99 [872]	92 [808]	411 [3640]	0.90 [8.00]	13.0 [115]
	VT115-016	16:1	246 [2174]	227 [2010]	206 [1827]	518 [4577]	1.10 [9.70]	24.6 [218]
	VT115-020	20:1	249 [2205]	231 [2046]	221 [1954]	524 [4637]	1.10 [9.70]	21.9 [194]
	VT115-025	25:1	241 [2131]	224 [1985]	216 [1908]	506 [4477]	1.10 [9.70]	21.9 [194]
	VT115-028	28:1	254 [2248]	237 [2098]	228 [2018]	533 [4718]	0.94 [8.30]	19.0 [168]
	VT115-035	35:1	246 [2172]	230 [2033]	221 [1959]	514 [4549]	0.79 [7.00]	18.8 [167]
	VT115-040	40:1	259 [2291]	243 [2149]	234 [2075]	542 [4794]	0.79 [7.00]	24.7 [219]
VT115-050	50:1	250 [2212]	235 [2081]	228 [2012]	521 [4615]	0.78 [6.90]	21.7 [192]	
VT115-070	70:1	237 [2094]	223 [1977]	217 [1916]	491 [4349]	0.78 [6.90]	19.0 [168]	
VT115-100	100:1	153 [1354]	134 [1185]	126 [1112]	459 [4059]	0.78 [6.90]	15.5 [137]	
VT014	VT014-004	4:1	518 [4583]	387 [3427]	332 [2940]	1066 [9431]	6.51 [57.60]	49.5 [438]
	VT014-005	5:1	504 [4459]	403 [3571]	347 [3064]	1040 [9206]	5.02 [44.40]	45.9 [407]
	VT014-007	7:1	483 [4274]	430 [3809]	369 [3268]	1002 [8866]	3.80 [33.60]	42.3 [378]
	VT014-010	10:1	275 [2426]	235 [2075]	217 [1919]	956 [8459]	3.39 [30.00]	31.5 [280]
	VT014-016	16:1	579 [5119]	532 [4704]	503 [4456]	1206 [10674]	4.21 [37.20]	52.2 [463]
	VT014-020	20:1	587 [5195]	542 [4795]	518 [4583]	1224 [10832]	4.07 [36.00]	48.6 [431]
	VT014-025	25:1	567 [5021]	526 [4654]	504 [4459]	1183 [10463]	4.07 [36.00]	48.6 [431]
	VT014-028	28:1	599 [5303]	556 [4926]	534 [4725]	1248 [11047]	3.53 [31.20]	42.3 [375]
	VT014-035	35:1	579 [5122]	539 [4774]	518 [4589]	1204 [10653]	2.99 [26.40]	39.6 [352]
	VT014-040	40:1	612 [5413]	572 [5055]	550 [4867]	1271 [11248]	2.99 [26.40]	52.2 [461]
VT014-050	50:1	509 [5223]	553 [4893]	534 [4720]	1224 [10831]	2.85 [25.20]	48.6 [431]	
VT014-070	70:1	559 [4949]	527 [4657]	509 [4504]	1155 [10223]	2.85 [25.20]	44.1 [392]	
VT014-100	100:1	367 [3246]	320 [2838]	301 [2659]	1081 [9564]	2.85 [25.20]	31.5 [281]	
VT018	VT018-004	4:1	1203 [10649]	866 [7658]	743 [6570]	2242 [21609]	25.90 [229.00]	137.7 [1222]
	VT018-005	5:1	1174 [10385]	902 [7981]	774 [6847]	2389 [21143]	20.00 [177.00]	135 [1197]
	VT018-007	7:1	1128 [9878]	962 [8512]	825 [7303]	2309 [20429]	14.60 [129.00]	120.6 [1067]
	VT018-010	10:1	645 [5710]	550 [4864]	507 [4486]	2210 [19561]	13.00 [115.00]	90.9 [804]
	VT018-016	16:1	1356 [12005]	1238 [10963]	1125 [9959]	2800 [24779]	16.10 [142.00]	144.9 [1286]
	VT018-020	20:1	1378 [12194]	1265 [11191]	1203 [10649]	2846 [25187]	15.60 [138.00]	140.4 [1244]
	VT018-025	25:1	1333 [11799]	1229 [10877]	1174 [10385]	2754 [24370]	15.60 [138.00]	117.9 [1044]
	VT018-028	28:1	1409 [12466]	1301 [11518]	1245 [11013]	2910 [25751]	13.50 [119.00]	124.2 [1103]
	VT018-035	35:1	1362 [120490]	1263 [11178]	1211 [10714]	2810 [24870]	11.40 [101.00]	111.6 [988]
	VT018-040	40:1	1439 [12739]	1338 [11846]	1285 [11371]	2970 [2611]	11.40 [101.00]	144.9 [1286]
VT018-050	50:1	1390 [12301]	1297 [11479]	1247 [11042]	2863 [25338]	10.90 [96.00]	140.4 [1244]	
VT018-070	70:1	1319 [11667]	1236 [10339]	1193 [10555]	2707 [23959]	10.90 [96.00]	124.2 [1103]	
VT018-100	100:1	868 [7676]	757 [6698]	708 [6269]	2537 [22454]	10.90 [96.00]	92.7 [817]	
VT022	VT022-004	4:1	1815 [16065]	1306 [11554]	1121 [9913]	4180 [36986]	87.00 [7.70]	386 [3414]
	VT022-005	5:1	1892 [16740]	1360 [12038]	1167 [10328]	4093 [36225]	73.40 [6.50]	372 [3295]
	VT022-007	7:1	1838 [16268]	1452 [12844]	1245 [11019]	3933 [34804]	62.60 [5.55]	326 [2891]
	VT022-010	10:1	1050 [9293]	893 [8097]	823 [7277]	3871 [34254]	56.90 [5.04]	227 [2012]
	VT022-016	16:1	2218 [19625]	1979 [17513]	1697 [15025]	4722 [41793]	87.30 [7.73]	392 [3472]
	VT022-020	20:1	2254 [19948]	2062 [18246]	1815 [16065]	4791 [42396]	73.60 [6.52]	392 [3470]
	VT022-025	25:1	2184 [19332]	2009 [17781]	1892 [16745]	4636 [41025]	73.10 [6.47]	376 [3329]
	VT022-028	28:1	2304 [20394]	2125 [18803]	2008 [17528]	4884 [43224]	62.70 [5.55]	391 [3469]
	VT022-035	35:1	2233 [19765]	2067 [18294]	1976 [17494]	4719 [41757]	62.50 [5.53]	376 [3328]
	VT022-040	40:1	2357 [20864]	2188 [19359]	2095 [18542]	4972 [43999]	57.20 [5.06]	391 [3466]
VT022-050	50:1	2282 [20199]	2125 [18808]	2040 [18056]	4795 [42440]	57.10 [5.05]	376 [3326]	
VT022-070	70:1	2165 [19159]	2026 [17930]	1951 [17270]	4523 [40023]	57.00 [5.04]	329 [2903]	
VT022-100	100:1	1414 [12512]	1232 [10904]	1155 [10220]	4367 [38647]	56.90 [5.04]	228 [2014]	

All ratios in frame size 60, 75, 100 and 140 are available to ship in 24 hours through the Gearhead Express Program.

www.thomsonlinear.com

75

MICRON**ValueTRUE™ Helical Right Angle Gearheads**

Right Angle Torque: VTR006 - VTR075

Performance Specifications

Part Number	Ratio	20000 Hour Life			T _{peak} Nm [in.-lb.]	J kg-cm ² [in.-lb.-sec ² ×10 ⁻⁴]	Torsional Stiffness Nm/arc-min [in.-lb./arc-min]	
		T _r (1000 rpm) Nm [in.-lb.]	T _r (3000 rpm) Nm [in.-lb.]	T _r (5000 rpm) Nm [in.-lb.]				
VTR006	VTR006-008	8:1	44 [390]	41 [358]	34 [303]	95 [844]	0.50 [4.43]	1.89 [16.7]
	VTR006-010	10:1	43 [382]	40 [350]	36 [319]	92 [812]	0.49 [4.34]	1.62 [14.3]
	VTR006-012	12:1	41 [358]	37 [327]	33 [295]	98 [868]	0.39 [3.45]	1.80 [15.9]
	VTR006-014	14:1	41 [358]	38 [335]	37 [327]	87 [773]	0.49 [4.34]	2.16 [19.1]
	VTR006-015	15:1	44 [390]	41 [366]	40 [350]	95 [836]	0.39 [3.45]	2.16 [19.1]
	VTR006-016	16:1	30 [263]	27 [239]	24 [215]	99 [876]	0.39 [3.45]	2.16 [19.1]
	VTR006-020	20:1	37 [327]	34 [303]	31 [271]	95 [844]	0.39 [3.45]	2.16 [19.1]
	VTR006-025	25:1	31 [271]	28 [247]	25 [223]	96 [852]	0.38 [3.36]	2.07 [18.3]
	VTR006-028	28:1	42 [374]	40 [350]	39 [342]	90 [797]	0.39 [3.45]	1.98 [18.3]
	VTR006-030	30:1	25 [223]	22 [191]	21 [183]	84 [741]	0.42 [3.72]	2.07 [18.3]
	VTR006-035	35:1	43 [382]	40 [350]	35 [311]	91 [804]	0.38 [3.36]	2.07 [18.3]
	VTR006-040	40:1	26 [231]	23 [199]	22 [191]	85 [749]	0.39 [3.45]	2.16 [19.1]
VTR006-050	50:1	27 [239]	23 [207]	22 [191]	85 [749]	0.38 [3.36]	2.16 [19.1]	
VTR075	VTR075-008	8:1	80 [709]	73 [645]	70 [621]	170 [1505]	1.90 [16.81]	4.23 [37.4]
	VTR075-010	10:1	77 [685]	71 [629]	68 [605]	165 [1458]	1.90 [16.81]	3.69 [32.7]
	VTR075-012	12:1	82 [725]	76 [669]	73 [645]	175 [1545]	1.50 [13.28]	4.14 [36.6]
	VTR075-014	14:1	74 [653]	68 [605]	66 [581]	157 [1386]	1.90 [16.81]	5.94 [52.6]
	VTR075-015	15:1	79 [701]	74 [653]	70 [621]	168 [1489]	1.50 [13.28]	6.03 [53.4]
	VTR075-016	16:1	84 [741]	77 [685]	75 [661]	177 [1569]	1.50 [13.28]	6.03 [53.4]
	VTR075-020	20:1	80 [709]	75 [661]	72 [637]	171 [1513]	1.50 [13.28]	5.85 [51.8]
	VTR075-025	25:1	82 [725]	77 [677]	72 [637]	173 [1529]	1.50 [13.28]	5.76 [51.0]
	VTR075-028	28:1	77 [677]	72 [637]	69 [613]	161 [1426]	1.50 [13.28]	5.31 [47.0]
	VTR075-030	30:1	45 [398]	40 [350]	37 [327]	149 [1322]	1.60 [14.16]	5.67 [47.0]
	VTR075-035	35:1	77 [685]	73 [645]	70 [621]	163 [1442]	1.50 [13.28]	5.67 [50.2]
	VTR075-040	40:1	47 [414]	41 [358]	38 [335]	151 [1338]	1.50 [13.28]	6.03 [53.4]
VTR075-050	50:1	48 [422]	42 [374]	40 [350]	153 [1354]	1.50 [13.28]	5.94 [52.6]	

¹ Ratios are exact, higher ratios are also available, consult factory.
T_r = Rated output torque at rated speed for specific hours of life.

T_{peak} = Allowable momentary peak torque for emergency stop or heavy shock loading.
J = Mass moment of inertia reflected to the input shaft (including pinion assembly).

TRUE™ Planetary Gearheads

ValueTRUE Helical Right Angle Gearheads

Right Angle Torque: VTR090 - VTR010

Performance Specifications

Part Number	Ratio	20000 Hour Life			T _{peak} Nm [in.-lb.]	J kg-cm ² [in.-lb.-sec ² x10 ⁻⁴]	Torsional Stiffness Nm/arc-min [in.-lb./arc-min]	
		T _r (1000 rpm) Nm [in.-lb.]	T _r (3000 rpm) Nm [in.-lb.]	T _r (5000 rpm) Nm [in.-lb.]				
VTR090	VTR090-008	8:1	80 [709]	73 [345]	70 [621]	170 [1505]	1.90 [16.81]	4.23 [37.4]
	VTR090-010	10:1	77 [685]	71 [629]	68 [605]	165 [1458]	1.90 [16.81]	3.69 [32.7]
	VTR090-012	12:1	82 [725]	76 [669]	73 [645]	175 [1545]	1.50 [13.28]	4.14 [36.6]
	VTR090-014	14:1	74 [653]	68 [605]	66 [581]	157 [1386]	1.90 [16.81]	5.94 [52.6]
	VTR090-015	15:1	79 [701]	74 [653]	70 [621]	168 [1489]	1.50 [13.28]	6.03 [53.4]
	VTR090-016	16:1	84 [741]	77 [685]	75 [661]	177 [1569]	1.50 [13.28]	6.03 [53.4]
	VTR090-020	20:1	80 [709]	75 [661]	72 [637]	171 [1513]	1.50 [13.28]	5.85 [51.8]
	VTR090-025	25:1	82 [725]	77 [677]	72 [637]	173 [1529]	1.50 [13.28]	5.76 [51.0]
	VTR090-028	28:1	77 [677]	72 [637]	69 [613]	161 [1426]	1.50 [13.28]	5.31 [47.0]
	VTR090-030	30:1	45 [398]	40 [350]	37 [327]	149 [1322]	1.60 [14.16]	5.67 [50.2]
	VTR090-035	35:1	77 [685]	73 [645]	70 [621]	163 [1442]	1.50 [13.28]	5.67 [50.2]
	VTR090-040	40:1	47 [414]	41 [358]	38 [335]	151 [1338]	1.50 [13.28]	6.03 [53.4]
VTR090-050	50:1	48 [422]	42 [374]	40 [350]	153 [1354]	1.50 [13.28]	5.94 [52.6]	
VTR010	VTR010-004	4:1	234 [2071]	195 [1728]	167 [1673]	492 [4357]	3.30 [29.20]	14.94 [132.2]
	VTR010-005	5:1	228 [2015]	203 [1800]	175 [1649]	478 [4229]	3.30 [29.20]	11.79 [104.3]
	VTR010-008	8:1	234 [2071]	195 [1728]	167 [1673]	492 [4357]	3.30 [29.20]	14.94 [132.2]
	VTR010-010	10:1	228 [2015]	203 [1800]	175 [1649]	478 [4229]	3.30 [29.20]	11.79 [104.3]
	VTR010-012	12:1	243 [2151]	221 [1951]	189 [1744]	508 [4492]	2.60 [23.01]	16.92 [149.7]
	VTR010-014	14:1	217 [1920]	200 [1768]	186 [1649]	455 [4030]	3.30 [29.20]	20.79 [184.0]
	VTR010-015	15:1	233 [2063]	216 [1912]	197 [1744]	491 [4349]	2.50 [22.12]	21.87 [193.5]
	VTR010-016	16:1	225 [1991]	205 [1816]	185 [1641]	518 [4580]	2.60 [23.01]	22.32 [197.5]
	VTR010-020	20:1	238 [2103]	221 [1951]	212 [1872]	500 [4421]	2.60 [23.01]	19.89 [176.0]
	VTR010-025	25:1	211 [1864]	193 [1705]	174 [1532]	506 [4476]	2.50 [22.12]	19.89 [176.0]
	VTR010-028	28:1	226 [1999]	211 [1854]	203 [1792]	473 [4190]	2.60 [23.01]	17.28 [152.9]
	VTR010-030	30:1	132 [1171]	115 [1020]	107 [948]	439 [3887]	2.80 [24.78]	17.19 [152.9]
	VTR010-035	35:1	229 [2023]	214 [1896]	206 [1824]	479 [4237]	2.50 [22.12]	17.10 [152.1]
	VTR010-040	40:1	137 [1211]	119 [1051]	112 [988]	445 [3935]	2.60 [23.01]	22.41 [198.3]
	VTR010-050	50:1	140 [1243]	122 [1083]	115 [1020]	448 [3967]	2.50 [22.12]	19.71 [174.4]

¹ Ratios are exact, higher ratios are also available, consult factory.
T_r = Rated output torque at rated speed for specific hours of life.

T_{peak} = Allowable momentary peak torque for emergency stop or heavy shock loading.
J = Mass moment of inertia reflected to the input shaft (including pinion assembly).

MICRON**ValueTRUE™ Helical Right Angle Gearheads**

Right Angle Torque: VTR115, VTR014, VTR018

Performance Specifications

Part Number	Ratio	20000 Hour Life			T _{peak} Nm [in.-lb.]	J kg-cm ² [in.-lb.-sec ² x10 ⁻⁴]	Torsional Stiffness Nm/arc-min [in.-lb./arc-min]	
		T _r (1000 rpm) Nm [in.-lb.]	T _r (3000 rpm) Nm [in.-lb.]	T _r (5000 rpm) Nm [in.-lb.]				
VTR115	VTR115-004	4:1	234 [2071]	195 [1728]	167 [1481]	492 [4357]	3.30 [29.20]	14.94 [132.2]
	VTR115-005	5:1	228 [2015]	203 [1800]	175 [1545]	478 [4229]	3.30 [29.20]	11.79 [104.3]
	VTR115-008	8:1	234 [2071]	195 [1728]	167 [1481]	492 [4357]	3.30 [29.20]	14.94 [132.2]
	VTR115-010	10:1	228 [2015]	203 [1800]	175 [1545]	478 [4229]	3.30 [29.20]	11.79 [104.3]
	VTR115-012	12:1	243 [2151]	221 [1951]	189 [1673]	508 [4492]	2.60 [23.01]	16.92 [149.7]
	VTR115-014	14:1	217 [1920]	200 [1768]	186 [1649]	455 [4030]	3.30 [29.20]	20.79 [184.0]
	VTR115-015	15:1	233 [2063]	216 [1912]	197 [1744]	491 [4349]	2.50 [22.12]	21.87 [193.5]
	VTR115-016	16:1	225 [1991]	205 [1816]	185 [1641]	518 [4580]	2.60 [23.01]	22.32 [197.3]
	VTR115-020	20:1	238 [2103]	221 [1951]	212 [1872]	500 [4421]	2.60 [23.01]	19.89 [176.0]
	VTR115-025	25:1	211 [1864]	193 [1705]	174 [1537]	506 [4476]	2.50 [22.12]	19.89 [176.0]
	VTR115-028	28:1	226 [1999]	211 [1864]	203 [1792]	473 [4190]	2.60 [23.01]	17.28 [152.9]
	VTR115-030	30:1	132 [1171]	115 [1020]	107 [948]	439 [3887]	2.80 [24.78]	17.19 [152.1]
	VTR115-035	35:1	229 [2023]	214 [1896]	203 [1824]	479 [4237]	2.50 [22.12]	17.10 [151.3]
VTR115-040	40:1	137 [1211]	119 [1051]	112 [988]	445 [3935]	2.60 [23.01]	22.41 [198.3]	
VTR115-050	50:1	140 [1243]	122 [1083]	115 [1020]	448 [3967]	2.50 [22.12]	19.71 [174.4]	
VTR014	VTR014-004	4:1	550 [4867]	477 [4221]	409 [3616]	1142 [10108]	16.00 [141.60]	33.03 [292.0]
	VTR014-005	5:1	534 [4723]	485 [4293]	427 [3775]	1110 [9821]	16.00 [141.60]	28.71 [254.0]
	VTR014-008	8:1	550 [4867]	477 [4221]	409 [3616]	1142 [10108]	16.00 [141.60]	33.03 [292.0]
	VTR014-010	10:1	534 [4723]	485 [4293]	427 [3775]	1110 [9821]	16.00 [141.60]	28.71 [254.0]
	VTR014-012	12:1	567 [5018]	518 [4580]	462 [4086]	1182 [10458]	13.00 [115.05]	19.89 [176.0]
	VTR014-014	14:1	509 [4500]	466 [4126]	444 [3927]	1061 [9391]	16.00 [141.60]	46.44 [411.0]
	VTR014-015	15:1	549 [4859]	504 [4460]	480 [4245]	1145 [10131]	12.00 [106.20]	46.53 [412.0]
	VTR014-016	16:1	525 [4644]	479 [4237]	433 [3831]	1206 [10673]	13.00 [115.05]	47.52 [421.0]
	VTR014-020	20:1	560 [4954]	517 [4572]	493 [4365]	1166 [10323]	13.00 [115.05]	44.28 [392.0]
	VTR014-025	25:1	532 [4707]	494 [4373]	474 [4198]	1183 [10466]	13.00 [115.05]	38.52 [341.0]
	VTR014-028	28:1	532 [4707]	494 [4373]	474 [4198]	1108 [9805]	13.00 [115.05]	38.52 [341.0]
	VTR014-030	30:1	317 [2804]	275 [2429]	256 [2262]	1029 [9104]	14.00 [123.90]	40.23 [356.0]
	VTR014-035	35:1	539 [4771]	502 [4444]	483 [4277]	1121 [9924]	12.00 [106.20]	36.18 [320.0]
VTR014-040	40:1	328 [2899]	285 [2525]	266 [2350]	1043 [9231]	13.00 [115.05]	47.34 [419.0]	
VTR014-050	50:1	338 [2987]	293 [2597]	275 [2429]	1054 [9327]	12.00 [106.20]	44.28 [392.0]	
VTR018	VTR018-004	4:1	1285 [11374]	1066 [9431]	914 [8092]	2636 [23329]	45 [398]	102 [900]
	VTR018-005	5:1	1247 [11039]	1111 [9829]	952 [8427]	2566 [22708]	45 [398]	83 [733]
	VTR018-008	8:1	1285 [11374]	1066 [9431]	914 [8092]	2636 [23329]	45 [398]	102 [900]
	VTR018-010	10:1	1247 [11039]	1111 [9829]	952 [8427]	2566 [22708]	45 [398]	83 [733]
	VTR018-012	12:1	1328 [11748]	1203 [10649]	1032 [9136]	2736 [24214]	36 [319]	57 [502]
	VTR018-014	14:1	1193 [10554]	1085 [9606]	1016 [8992]	2460 [21768]	45 [398]	100 [884]
	VTR018-015	15:1	1287 [11390]	1174 [10386]	1076 [9518]	2655 [23497]	35 [310]	130 [1147]
	VTR018-016	16:1	1199 [10609]	1094 [9685]	989 [8754]	2800 [24779]	36 [319]	132 [1171]
	VTR018-020	20:1	1314 [11629]	1205 [10665]	1148 [10155]	2713 [24007]	36 [319]	128 [1131]
	VTR018-025	25:1	1054 [9327]	962 [8515]	870 [7702]	2754 [24373]	35 [310]	107 [948]
	VTR018-028	28:1	1251 [11071]	1156 [10227]	1105 [9781]	2583 [22860]	36 [319]	113 [1004]
	VTR018-030	30:1	747 [6611]	645 [5711]	600 [5313]	2399 [21227]	38 [336]	102 [900]
	VTR018-035	35:1	1268 [11223]	1176 [10410]	1128 [9980]	2617 [23162]	35 [310]	102 [900]
VTR018-040	40:1	775 [6858]	671 [5942]	626 [5536]	2437 [21569]	36 [319]	132 [1171]	
VTR018-050	50:1	796 [7048]	691 [6117]	645 [5711]	2465 [21816]	35 [310]	128 [1131]	

¹ Ratios are exact, higher ratios are also available, consult factory.
T_r = Rated output torque at rated speed for specific hours of life.

T_{peak} = Allowable momentary peak torque for emergency stop or heavy shock loading.
J = Mass moment of inertia reflected to the input shaft (including pinion assembly).

Radial and Axial Load Ratings

VT006

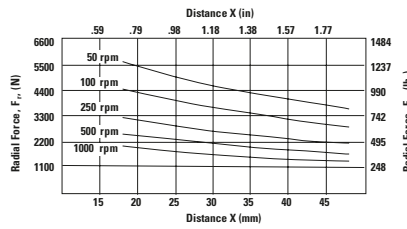
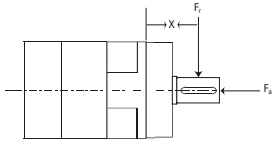

Speed rpm	Axial Load, F_a N [lb.]
50	7198 [1618]
100	5710 [1284]
250	4208 [946]
500	3342 [751]
1000	2652 [596]

VT075 and VT090

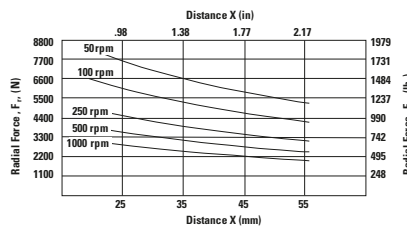
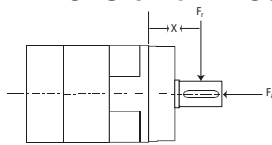

Speed rpm	Axial Load, F_a N [lb.]
50	9903 [2227]
100	7863 [1768]
250	5793 [1303]
500	4599 [1034]
1000	3650 [821]

VT010 and VT115

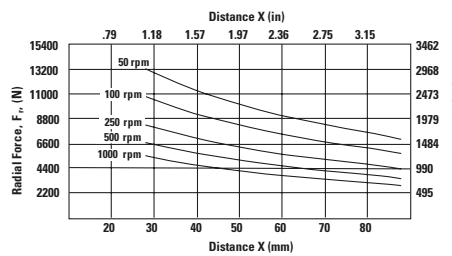
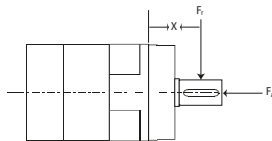

Speed rpm	Axial Load, F_a N [lb.]
50	13,675 [3075]
100	11,107 [2497]
250	8435 [1897]
500	6855 [1542]
1000	5568 [1252]

VT014

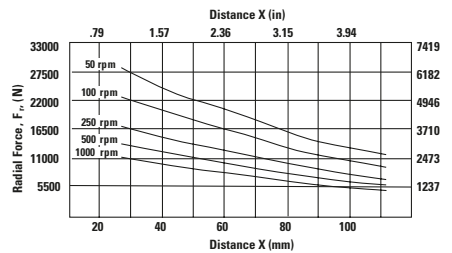
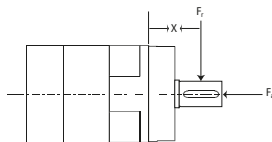

Speed rpm	Axial Load, F_a N [lb.]
50	25,374 [5705]
100	20,609 [4633]
250	15,657 [3520]
500	12,716 [2859]
1000	10,329 [2322]

VT018

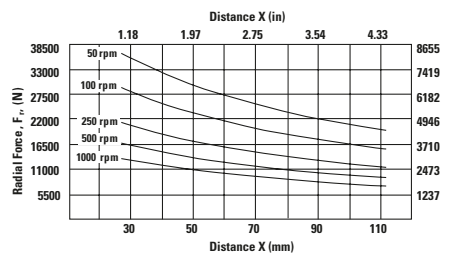
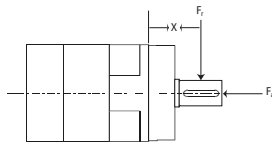

Speed rpm	Axial Load, F_a N [lb.]
50	34,538 [7765]
100	27,414 [6163]
250	20,197 [4541]
500	16,034 [3605]
1000	12,726 [2861]

VT022

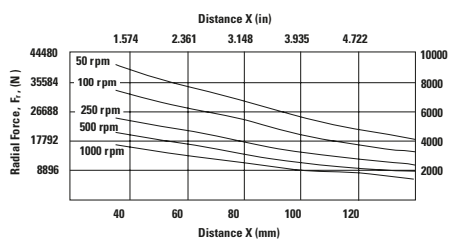
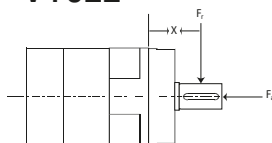

Speed rpm	Axial Load, F_a N [lb.]
50	32,351 [3655]
100	26,277 [2969]
250	19,962 [2256]
500	16,214 [1832]

These graphs display the allowable radial load at a given distance (X) from the mounting surface based on an L₁₀ life of 10,000 hours for the mean output speed n_{mout} , as described on page 9.

MICRON

Radial and Axial Load Ratings

VTR006

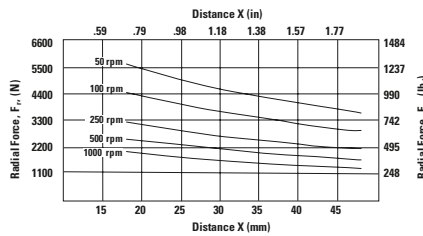
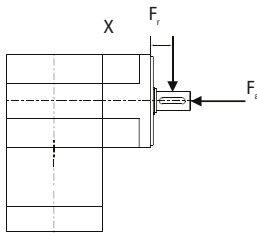

Speed rpm	Axial Load, F_a N [lb.]
50	7198 [1618]
100	5710 [1284]
250	4208 [946]
500	3342 [751]
1000	2652 [596]

VTR075 and VTR090

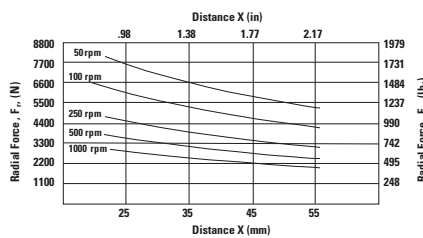
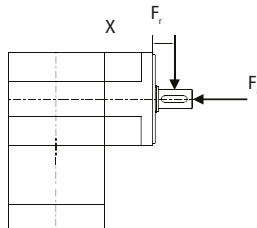

Speed rpm	Axial Load, F_a N [lb.]
50	9903 [2227]
100	7863 [1768]
250	5793 [1303]
500	4599 [1034]
1000	3650 [821]

VTR010 and VTR115

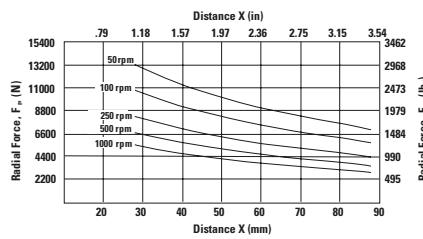
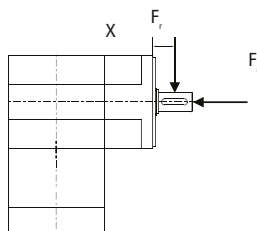

Speed rpm	Axial Load, F_a N [lb.]
50	13,675 [3075]
100	11,107 [2497]
250	8435 [1897]
500	6855 [1542]
1000	5568 [1252]

VTR014

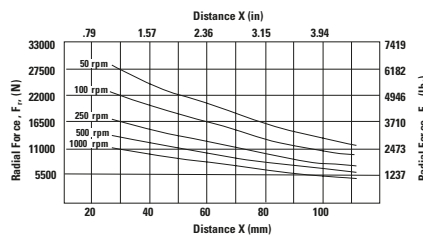
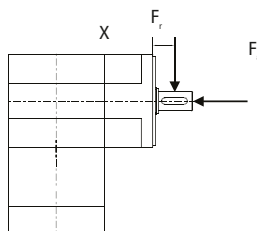

Speed rpm	Axial Load, F_a N [lb.]
50	25,374 [5705]
100	20,609 [4633]
250	15,657 [3520]
500	12,716 [2859]
1000	10,329 [2322]

VTR018

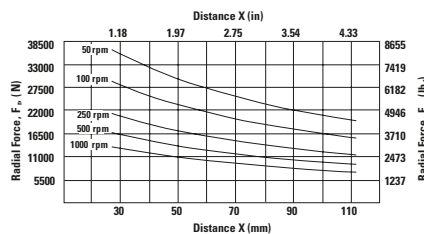
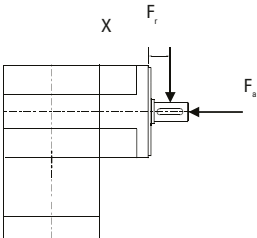

Speed rpm	Axial Load, F_a N [lb.]
50	34,538 [7765]
100	27,414 [6163]
250	20,197 [4541]
500	16,034 [3605]
1000	12,726 [2861]

These graphs display the allowable radial load at a given distance (X) from the mounting surface based on an L_{10} life of 10,000 hours for the mean output speed n_{mout} , as described on page 9.

TRUE™ Planetary Gearheads

